

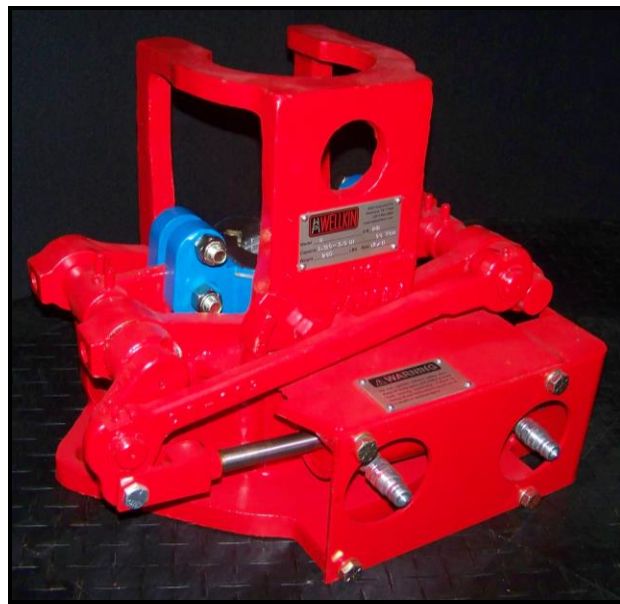

Model B Tubing Spider
Installation, Operation, Service and Parts Book Manual



WPI WELLKIN Inc.
8401 Industrial Dr.
Pearland, TX 77584
PH: (281) 992-2064
FX: (281) 992-2076
E-mail: sales@wpiwellkin.com
Web: www.wpiwellkin.com

Terms and Conditions

1. All WPI WELLKIN packing slips and invoices must show Buyer's purchase order number.
2. All shipments MUST contain packing slips.
3. **CONTRACT:** This order will become a binding contract upon receipt by WPI WELLKIN of Buyer's PO, receipt by Buyer of a written acknowledgement by WPI WELLKIN and receipt by WPI WELLKIN of a down payment in the amount specified in the contract.
4. This contract may be modified as mutually agreed by the Buyer and WPI WELLKIN.
5. **PAYMENT TERMS:** The payment terms are specified on the commercial offer from WPI WELLKIN. The Buyer agrees to the payment terms by acceptance of the bid.
6. **DELIVERY:** Time is of the essence. WPI WELLKIN will attempt to deliver the material early if possible. WPI WELLKIN will make best efforts to supply all material on a timely basis. If the delivery will run over the contract delivery date, WPI WELLKIN will notify the Buyer giving reason for delay. The current delivery estimate is specified on the commercial offer. The Buyer agrees to the delivery terms by acceptance of the bid.

When necessary, WPI WELLKIN will notify the Buyer in advance of completion of the order and Buyer will appoint an authorized representative or employee to inspect the material on a date and site as designated by WPI WELLKIN. Transportation, lodging and all other expenses portal to portal for Buyer representative or employee to witness and accept the material is the expense of the Buyer.

All costs associated with preparation, crating, insurance and ocean freight of the goods to the final destination to be at Buyer's expense.

7. **CANCELLATION:** This contract is considered to be special order and not subject to cancellation. Both parties hereto shall be given consideration in case of delays in delivery caused by fire, strike, riot, war, act of God, delay of carriers, governmental order or regulation, complete or partial shutdown of plant by reason of inability to obtain sufficient raw materials or power or any other similar or different contingency beyond the reasonable control of the respective parties.
8. **WARRANTIES AND REMEDIES:** WPI WELLKIN expressly warrants that all supplies, materials and parts covered by this contract will conform to the specifications in the contract as applicable and will meet or exceed industry standards for such equipment. WPI WELLKIN will supply Buyer with operations manuals and parts books for the material where applicable. Certificates of Compliance are available upon request.

MANUFACTURED ITEMS: WPI WELLKIN manufactured items must be free of material and workmanship defects for a period of 12 months from the date of delivery. If any items fail because of a manufacturing defect within that period of time, then that item will be replaced by WPI WELLKIN. Expendable / wear items are not covered under warranty. Examples of such items include, but are not limited to, the following - dies, inserts, brake bands, rollers, gears, chains, filters, belts, flexible couplings, slip bodies, spider bowls.

Replacement of parts will be accomplished at WPI WELLKIN's facility or at a designated service point. WPI WELLKIN's liability is limited to replacement of defective parts only and does not include the cost of labor, communications, transportation or handling connected to the replacement of these parts. WPI WELLKIN will in no event be liable for consequential damages or contingent liabilities arising out of the failure of any parts to operate properly. No expressed, implied or statutory guarantee other than herein set forth is made or authorized to be made by WPI WELLKIN.

DISTRIBUTED ITEMS: Items distributed by WPI WELLKIN are subject to the warranty provided by the Original Equipment Manufacturer (OEM). Upon request, WPI WELLKIN will furnish Buyer with a warranty statement from the OEM for the applicable material. The OEM warranty will start on the items' delivery date.

9. **COMMISSIONING:** On request, WPI WELLKIN can supply a representative for material commissioning. The Buyer is responsible for portal to portal transportation costs and the current WPI WELLKIN day rate.

10. **BUYER'S PROPERTY:** All equipment or material furnished by WPI WELLKIN shall be the property of the Buyer after the WPI WELLKIN invoice is paid in full.

11. **PATENTS:** WPI WELLKIN holds the Buyer harmless from all claims, for infringement or alleged infringement of any patents arising out of the sale or use of the goods furnished pursuant to this contract.

12. **INDEPENDENT CONTRACT:** In the event that any goods ordered hereunder require in connection with the installation thereof, the services of a contractor engaged by WPI WELLKIN or a supervisor, engineer, or other employee connected with or employed by WPI WELLKIN, and WPI WELLKIN agrees to furnish same, either with or without charge, such contractor, supervisor, engineer, or other employee in performing such services shall not be deemed to be the agent or employee of the Buyer.

13. **INSURANCE:** WPI WELLKIN agrees to carry General Operations and Liability Insurance and other coverage as required in accordance with applicable state and federal laws of the U.S.A.

14. **COMPLIANCE WITH LAWS:** WPI WELLKIN warrants that in its performance of this contract it will comply with all applicable Federal, State and Local laws, regulations, rulings and orders of the U.S.A.

15. **ASSIGNMENT:** This contract may not be assigned without the written consent of the Buyer and any attempted assignment thereof shall be void.

16. **PROPRIETARY INFORMATION:** All plans, drawings, specification and the subject matter contained therein and all other information given to WPI WELLKIN in connection with performance on this Purchase Order involve valuable property rights of the Buyer and shall be held confidential by WPI WELLKIN, shall remain the property of the Buyer and shall not be used by WPI WELLKIN for any purpose other than those for which they have been prepared or supplied. WPI WELLKIN agrees that, as far as possible, it will keep confidential the making of this order and the terms hereof. WPI WELLKIN agrees not to use for publicity purposes any information as to notice of receipt of order, photographs, drawings and/or materials in connection with performance of the Order without obtaining the prior written consent of the Buyer.

Table of Contents

Terms and Conditions.....	2
Table of Contents	4
Spider Warnings	5
Spider General Information.....	6
Installation	6
Operation	7
Service.....	9
Parts Book	12

Spider Warnings

The tubing spider design integrates several safety features. However, the spider is only as safe as the operator using the unit. It is imperative that the operator and all other workers around the spider observe the warnings below. Failure to follow the instructions could result in **death, serious injury or equipment damage**.



- Observe, understand and follow all safety warnings.
- Never operate the spider above the rated design load.
- Use the correct size slip and insert. If the size does not match the tubing string, then the spider will not hold the tubing string.
- Do not operate without the gate closed and pinned.
- Keep all body parts and clothing away from moving machinery.
- Only trained personnel should operate, adjust or repair this equipment. Heat treated alloy steels are used in the construction of the spider. No weld repair on any components is allowed. Any attempts to repair these items by welding will void all warranties and liability.
- Turn off all power and disconnect the hydraulic/pneumatic connections from the equipment before performing any of the following. Also, relocate the spider to a work area to avoid dropping items down the well when disassembly will take place.
 - Performing repairs
 - Making adjustments
 - Lubricating the equipment
 - Changing slip inserts
- When the spider is used to hold the tubing string for extended periods of time, engage the safety latch. This feature prevents the accidental opening of the slips from the controls by stopping the link.

Spider General Information

Description

The purpose of a tubing spider is to hold the load of the tubing string as it is lowered or raised from the well. The spider is made up of 3 principal assemblies: the base, the slip and the actuator.

The base of the spider contains a machined taper that matches the slip bodies. It also has all of the mounts for the linkages that operate the slips. Installed on the slips are the inserts. The size of insert and slip matches the tubing string. During operation, a control valve is used to actuate a cylinder that opens or closes the slips. This actuator can be hydraulic or pneumatic.

Specifications

Load rating	110000 lbs (49895 Kg)
Size range	1.315 to 3-1/2" (33.4 to 88.9 mm)
Material	Heat treated alloy steel
Pressure requirements	
Hydraulic	300 to 500 PSI (20.7 to 34.5 bar)
Pneumatic	90 to 120 PSI (6.2 to 8.3 bar)
Weight	250 lbs (113.4 Kg)
Dimensions	
Gate opening	4-1/4" (107.9 mm)
Bowl opening	4-3/4" (120.6 mm)
Base	14" x 17" (355.6 mm x 431.8 mm)
Height	15-1/2" (393.7 mm)
Base bolt slot	
Slot width	1-1/4" (31.7 mm)
Slot centers	11-1/2 to 16-3/4" (292.1 to 425.5 mm)

Installation

Before any attempt is made to operate the tubing spider, the following section should be read, understood and then followed.

Control Valve

The tubing spider control valve is connected to the spider by a set of hoses. Always place this valve in a location that is easily accessed by the rig crew operator.

Hoses

Verify that the cylinder hoses do not present a trip hazard or interfere with any moving machinery. When connecting and disconnecting the hoses, ensure that there is no pressure on the lines.

Quick Disconnects

The hoses are fitted with quick disconnects. Before a connection is made, inspect the end faces of the quick disconnect. If any foreign material is present, then carefully remove the

debris with a lint free rag or towel. Dust caps and plugs should be used with the quick disconnects to protect the ends and minimize contact with debris.

Inspection

Before moving the spider over the well, ensure the correct size slip assembly and inserts match the tube diameter.

After the lines are connected, cycle the cylinder and observe the linkage system to see if there are any functional problems. Disconnect the lines before moving the tubing spider.

Mount

The spider must be secured over the wellhead. The slotted holes in the base could be used to bolt the spider to an adapter plate. There are also eyes on the spider where it can be chained down.

Operation

Verify the following before and during operation of the spider.

- Keep the insert teeth clean from buildup of mud, grease, sand or other debris.
- Lubricate the bushings via the grease fittings found along the linkage assembly.

Depending on the operation of the control valve, pressure applied to the cylinder will either cause it to extend or retract. This cylinder moves the slip assembly via lift arms, crank shafts and links.

Opening the Slips

Retracting the cylinder prevents the insert teeth from engaging and supporting the tubing string by moving the slip up and out of the way.

Closing the Slips

To engage the insert teeth on the tubing string, the cylinder is extended. Then, the load of the tubing string can be held if it is lowered slightly thereby transferring the load from the hook to the spider.

Objects Larger than Spider Bore

When an object is coming in or out of the well that has a diameter larger than the bore of the spider, then the tubing spider has to be removed. Ensure the weight of the tubing string is not being held by the spider. Remove the gate so the spider can be removed from the string. Pass the object, and reinstall the tubing spider over the well. Install the gate back onto the spider and pin it in place.

Slip Assembly

The slip assembly must correlate with the size of tubing being held. The following instructions are for the replacement of the slip assembly or inserts. Refer to the warning section of the manual before working on the spider.

Slip Replacement

Follow the steps below. Refer to the parts drawing in this manual for a visual aid.

1. Use the pneumatic or hydraulic system to hold the slip bodies in the raised position.
2. Loosen and remove the nut from the bolt that secures the slip to the lift arm. Lift the slip assembly out of the spider. Repeat for the other side.
3. Replace with the new slip assemblies with inserts already installed. *Note: The slip assembly halves are a machined set and must always be kept together.* Align the bottom slip hole with the hole in the lift arm and secure using a new bolt and nut. Tighten the nut until the end of the bolt is flush with the end of the nut. Repeat for the other side. Do not over tighten as it is necessary for the slip to float relative to the lift arm.
4. Function test the slip to verify correct operation before usage.

Insert Replacement

Use the following steps as a guide. Refer to the parts drawing in this manual for a visual aid.

1. Use the pneumatic or hydraulic system to hold the slip bodies in the raised position.
2. Remove the four cotter pins.
3. Using a 3/16" or 7/32" drift pin, remove the four retainer pins that are located in the hole formed between the slip body and slip insert.
4. Slide or drive the four slip inserts out of the slip body dove tail groove.
5. Clean the built up debris out of the slip body. Apply a new coating of grease to the slip body.
6. Install the new slip inserts by aligning the vertical groove in the insert with the slip body. *Note: Always replace inserts in a full set.*
7. Knock the retainer pins back into their corresponding holes.
8. Reinstall the four cotter pins or replace with new ones. Spread the legs of the pins to keep them from falling out.
9. Function test the slip to verify correct operation before usage.

Troubleshooting

The following table addresses possible solutions to problems that may occur during operation.

Table 1: Troubleshooting the Spider

Problem	Solution
Slip insert teeth are not gripping tubing	<ol style="list-style-type: none">1) Clean the teeth. Verify they are clean from built up debris such as dirt, mud, grease, sand, etc.2) Inspect the teeth for damage. Replace inserts if any of the teeth are worn, broken or chipped.3) Verify the insert is not too loose in the slip body. If the insert can move vertically 1/10" or more, then it is too loose. Replace the slip body assembly.4) Verify the correct size slip assembly and inserts are being used for the diameter of

	the tubing string.
Spider lift arms contact the spider body when the tubing is engaged	1) Inspect the bottom of the spider assembly. If the slip assembly extends past the bottom of the bowl, then replace the slip assembly. If the arms still contact the body, then inspect the bottom of the spider again. If the new slip extends below the bowl, then the spider base needs to be replaced.
Actuating cylinder does not function properly	1) Verify the pressure to the cylinder meets system requirements. 2) The seals could be worn inside the cylinder. Replace with new seals or replace the entire cylinder.
Linkage assembly loose or does not function properly	1) Inspect all bushings to see if they are worn and too loose on the pins. Replace with new bushings. 2) Inspect the crank shafts for wear. Replace if necessary. 3) Inspect the bolts at both end of the cylinder. Replace if there is any wear present.

Service

It is important to maintain the spider in a condition that will provide continued safe operation. The following sections highlight items that need to be addressed over the life of the unit.

Daily

1. Grease all fittings on the tubing spider.
2. Inspect inserts for debris or wear.
3. Verify linkages operate properly.

Semi-annual Maintenance

1. Perform all activities listed in the daily section.
2. Perform a Nondestructive Evaluation (NDE) on all exposed critical areas of the slip bodies, spider base, gate and door pins.
3. Replace the crank and link bushings.
4. Rebuild the cylinder with new seals.
5. Function test the spider to verify proper operation.
6. Record the maintenance activities on a log or report that is kept on file and can be traced back to the serial number of the spider.

Annual Maintenance

1. Perform all activities listed in the daily section.
2. Completely disassemble the spider.
3. NDE all critical components such as slip assembly, lift arms, cranks, link, gate door pins and attachment points on the spider base. Replace any worn or damaged parts.

-
4. Replace the crank shafts.
 5. Replace the crank and link bushings.
 6. Replace the cylinder.
 7. Inspect the fit between the door pins and the gate and body. Replace the pins if too loose.
 8. Assemble the tubing spider with the good or replacement parts.
 9. Function test the spider to verify proper operation.
 10. Record the maintenance activities on a log or report that is kept on file and can be traced back to the serial number of the spider.

Instructions for replacing the crank shafts and bushings can be found in the following text.

Bushing Replacement

Use the following steps as a guide. Refer to the parts drawing in this manual for a visual aid.

1. Use the pneumatic or hydraulic system to hold the slip bodies in the raised position.
2. Remove the slip assemblies per the instructions found in the operation section.
3. Release the pressure on the cylinder allowing it to extend. Bleed any remaining pressure out of the cylinder.
4. Loosen and remove the nut on the bolt that pins the cylinder yoke to the link. Remove the bolt, and rotate the cylinder so that the yoke is away from the link.
5. The link is held onto the left and right hand crank shafts by two external retaining rings. Remove these rings so the link can be removed.
6. There are two bushings in the link. Using a press or bushing puller, remove these bushings from the link and discard. Install two new bushings into the link. Set the link aside.
7. Rotate the lift arms so the taper pins are exposed. These taper pins connect the lift arms to the crank shafts. Drive out the taper pins and set aside.
8. Loosen and remove the set screws that hold the lift arms to the crank shafts. Set the set screws aside.
9. Remove the crank shafts from the spider by lightly tapping the ends. Set these aside along with the lift arms and spacers.
10. Bushings are located in the spider body in four locations. Using a press or bushing puller, remove these bushings from the body and discard. Install four new bushings into the body.
11. Reassemble the tubing spider.
 - a. Install the left hand crank shaft into the spider body. When inserting the shaft, put the spacer and lift arm back in their correct positions.
 - b. Repeat for the right hand crank shaft.
 - c. Install the link onto the left and right hand crank shafts. Hold the link arm onto the shafts by the two retaining rings.
 - d. Move the link to the left. Rotate and shift the lift arm on the crank shaft until the holes for the taper pins are aligned. Drive the taper pins back through the lift arm and crank shaft. Install the set screw and tighten to hold these two parts in relation to each other.
 - e. Repeat the above for the right hand crank shaft.
 - f. Align the cylinder yoke with the hole in the link. Insert the bolt and tighten the nut until the nut edge is flush with the end of the bolt.

- g. Install the slip assemblies back onto the lifting arms.
- h. Function test the spider to verify proper operation.

Crank Shaft and Lift Arm Replacement

Use the following steps as a guide. Refer to the parts drawing in this manual for a visual aid.

Note: The following procedure can be difficult. If there are any doubts to the successful completion of the repair, then consult with an authorized repair facility.

1. Replace the old cranks shafts and lift arms with new ones using the instructions in the bushing replacement section. Reassembly will stop when the taper pins are to be installed. The replacement crank shafts do not have holes drilled through them.
2. Ensure the crankshafts are slid into the spider body until they bottom out. This should position the back side of the link arm approximately 1/8" (3.2 mm) from the head of the safety latch bolt.
3. Position the lifting arms on the crank shaft so their midlines are centered with the bore of the spider body. Turn the lift arms in toward the spider body until they rest on top of the bowl.
4. Tighten the lift arm set screws to lock down their position relative to the crank shafts. Secure the position of the lift arms with tie downs so they may not move while being drilled.
5. Using the lift arm holes as a guide, center punch the crank shafts. Drill the four holes with an 11/32" drill bit. Ream the holes with a #7 tapered reamer.
6. Drive the taper pins back through the lift arm and crank shaft.
 - a. Align the cylinder yoke with the hole in the link. Insert the bolt and tighten the nut until the nut edge is flush with the end of the bolt.
 - b. Install the slip assemblies back onto the lifting arms.
 - c. Function test the spider to verify proper operation.

One Year Spares

Below is a list of recommended spares for one year of operation.

Table 2: Pneumatic Tubing Spider One Year Spares

Part Number	Qty.	Parts Description
65107	1	Yoke
65116	4	Bolt (For Slips)
TB-122	4	Shaft Retaining Clip
TB-124	4	Crank Shaft Bushing
TB-125	2	Link Bushing
TB-136	2	Safety Bolt
65140K	2	Pneumatic Cylinder Repair Kit w/ O-rings and Internal Retainer Rings
65140	1	Pneumatic Cylinder
65601	12	Retainer Pin
992005-07	4	Hex Head Cap Screw
992005-09	4	Hex Head Cap Screw
992012-44	12	Cotter Pin
TB-123	12	Grease Fitting
TB-118	4	Lift Arm Set Screw
992089-09	8	Hex Nut
992089-13	4	Nut
TB-119	4	Lift Arm Taper Pin

Table 3: Hydraulic Tubing Spider One Year Spares

Part Number	Qty.	Parts Description
65107	1	Yoke
65116	4	Bolt (For Slips)
TB-122	4	Shaft Retaining Clip
TB-124	4	Crank Shaft Bushing
TB-125	2	Link Bushing
TB-136	2	Safety Bolt
65140H	1	Hydraulic Cylinder
65601	12	Retainer Pin
992005-07	4	Hex Head Cap Screw
992005-09	4	Hex Head Cap Screw
992012-44	12	Cotter Pin
TB-123	12	Grease Fitting
TB-118	4	Lift Arm Set Screw
992089-09	8	Hex Nut
992089-13	4	Nut
TB-119	4	Lift Arm Taper Pin

Parts Book

Below are parts lists for the tubing spider and following are drawings with corresponding item numbers.

Table 4: Spider Parts List

Item	Part Number	Qty.	Part Description
1 & 2	60000-100	1	Type B Spider Assembly, Pneumatic
	60000H-100	1	Type B Spider Assembly, Hydraulic
3	TB-103	1	Link
4	TB-104	1	Left Hand Crank Shaft
5	TB-105	1	Right Hand Crank Shaft
6	TB-106	2	Lift Arm
7	65107	1	Yoke
8	TB-108	1	Safety Guard
9	TB-123	2	Grease Fitting
10	992005-09	1	Hex Head Cap Screw
11	992005-07	1	Hex Head Cap Screw
12	992089-09	2	Hex Nut
13	TB-113	4	Hex Head Cap Screw
14	TB-114	1	Nut for Gate
15	TB-115	1	Bolt for Gate
16	TB-118	2	Lift Arm Set Screw
17	TB-119	4	Lift Arm Taper Pin
18	TB-122	2	Shaft Retaining Clip
19	TB-124	4	Crank Shaft Bushing
20	TB-125	2	Link Bushing
21	TB-126	2	Spacer
22	992285-MH-6-6	2	Male Disconnect

Item	Part Number	Qty.	Parts Description
23	46053	2	Pipe Nipple
24	65135	1	Safety Latch
25	TB-136	1	Safety Bolt
26	65140	1	Pneumatic Cylinder
	65140H	1	Hydraulic Cylinder
	992308-4-6	2	1/4" MNPT x 3/8" FNPT Adapter for Hydraulic Cylinder
27	992107-15	1	Jam Nut
28	65116	4	Bolt
29	992089-13	4	Nut
30	65601	4	Retainer Pin
31	992012-44	4	Cotter Pin
32	992051-10	4	Lock Washer
Slip Bodies and Insert Sets			
33	60622-100	1	1.315 to 3-1/2" Slip Body Assembly
	65652-1.315	1	1.315" Slip Insert Set
	65652-1.660	1	1.660" Slip Insert Set
	65652-1.900	1	1.900" Slip Insert Set
	65652-2.060	1	2.060" Slip Insert Set
	65652-1	1	2-3/8" Slip Insert Set
	65652-2	1	2-7/8" Slip Insert Set
	65652-3.125	1	3-1/8" Slip Insert Set
	65652-3	1	3-1/2" Slip Insert Set
Pneumatic Cylinder Repair			
34	65141	1	Barrel
35	65142	1	Piston Rod
36	65143	1	End Seal
37	65150	1	Cylinder End Cap
38	65151	1	Piston Head
39	992116-13	1	Piston Lock Nut
40	992154-014	1	O-ring
41	992154-210	1	O-ring
42	992154-228	2	O-ring
43	992154-330	1	O-ring
44	992253-250	2	Internal Retainer Ring
	65140K	1	Pneumatic Cylinder Repair Kit w/ O-rings and Internal Retainer Rings
Hydraulic Cylinder Repair			
	65140H	1	Hydraulic Cylinder (Not field repairable)
Optional Parts			
	65200-100	1	Pneumatic Foot Control Valve Assembly
	65200H-100	1	Hydraulic Foot Control Valve Assembly
	65220-200	1	Pneumatic Hand Control Valve Assembly
	992311	1	Filter/Regulator/Lubricator Assembly with Gauge
	65300	1	Set of Pneumatic Hoses (Three 180" with QDs)
	65300H	1	Set of Hydraulic Hoses (Four 180" with QDs)
	992285-FH-6-6	6	Quick Disconnect (QD), Female

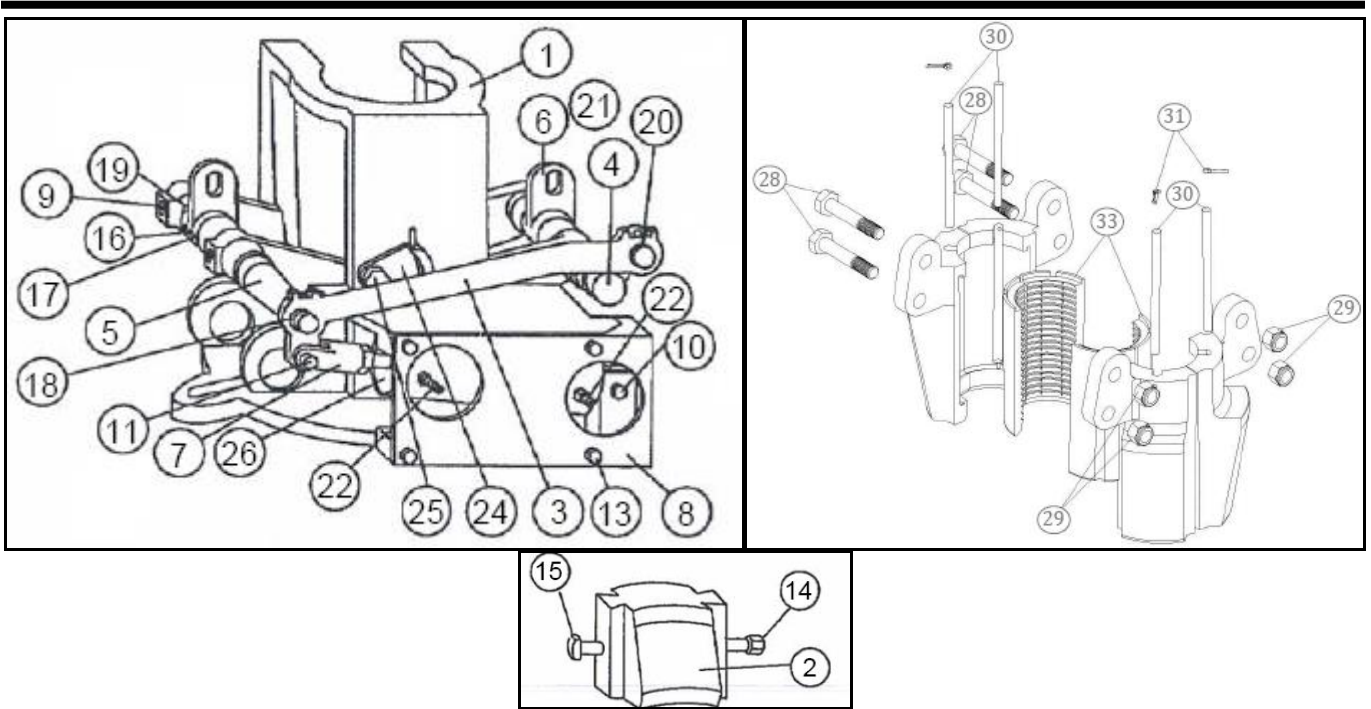

Figure 1: Tubing Spider Parts

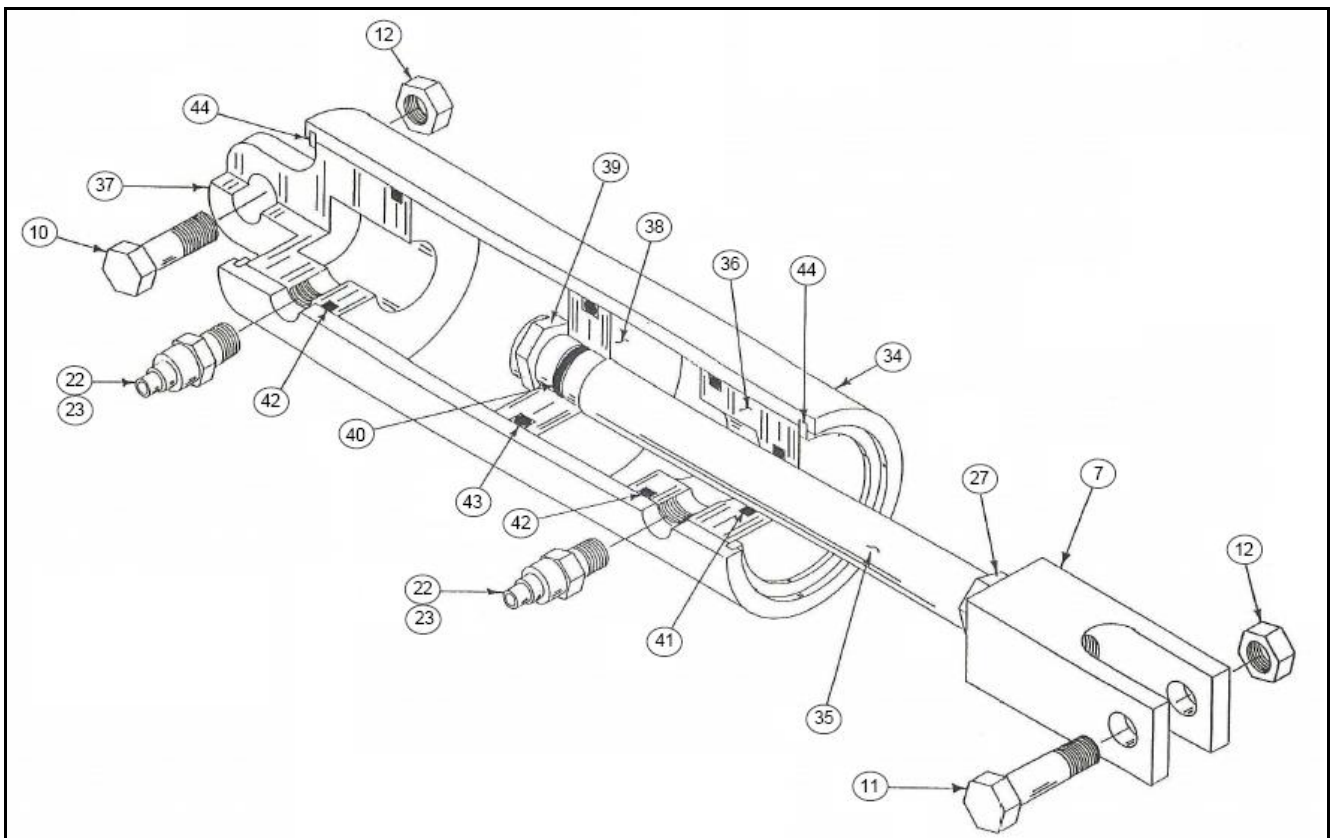

Figure 2: Pneumatic Cylinder Parts